

ADDENDUM ONE

Memorial Park Improvements
604 Hazel Street
Auburn, IN 46706

MARTINRILEY architects/engineers
221 West Baker Street
Fort Wayne, Indiana 46802
260-422-7994

Commission No.: F23059

Addendum Date: 19 July 2024

Conditions: The following clarifications, amendments, additions, deletions, revisions and modifications are a part of the contract documents and change the original documents only in the manner and to the extent stated.

Copies of the Addendum shall be bound with all contract sets of drawings and specifications.

CLARIFICATIONS:

Contractor Question#1
No questions at this time.

CHANGES TO THE SPECIFICATIONS:

Section 00 1113 *Advertisement for Bids*, **REPLACE** attached section to volume.
Section 00 2213 *Supplementary Instructions to Bidders*, **MODIFY** Article 10 Meetings, 10.1.1, to state, "... and Bidders will be held at 10:00 AM local time, 31 July 2024,..."

CHANGES TO DRAWINGS:

Sheet T101 - SEE ATTACHED SHEET for revisions:

- SHEET INDEX:
 - **UPDATE** to include S002, S102, S402

Sheet S102 - SEE ATTACHED SHEET:

- ADDED SHEET

Sheet S402 - SEE ATTACHED SHEET:

- ADDED SHEET

ATTACHMENTS:

00 1113 Advertisement for Bids.pdf

00 2213 Supplementary Instructions to Bidders.pdf

T101.pdf

S102.pdf

S402.pdf

END OF ADDENDUM NUMBER ONE

W:\2023 Projects\F23059 Memorial Park Auburn\Project Management\05-Bidding\Addendum 1

Invitation for Bid

Memorial Park Improvements Project

City of Auburn
210 East Ninth Street
Auburn, IN 46706
PH: 260-925-6450

Notice is hereby given, that the City of Auburn, DeKalb County, Indiana, by and through its Board of Public Works & Safety, hereinafter referred to as the Owner, will receive sealed bid packets for the construction of the Memorial Park Improvements Project.

Sealed bids must be received by the City of Auburn Clerk-Treasurer's Office at 210 East Ninth Street, Auburn, Indiana 46706 no later than 9:30 A.M. (Local Time) on Thursday, August 22, 2024. Bids received after such hour will be returned unopened. Bids received prior to this time shall be opened and publicly read at the public meeting scheduled to take place on Thursday, August 22, 2024, at 10:00 A.M., in the Norman E. Yoder Council Chambers located at 206 East Ninth Street, Auburn, IN 46706. All interested citizens are invited to attend. The City of Auburn will make reasonable accommodations to people with disabilities. Any person with special needs should contact the ADA Coordinator, Bill Brandon at (260) 925-6455 or the Clerk-Treasurer's Office at (260) 925-6450 at least 72 hours before the scheduled meeting to discuss necessary special accommodations.

A **pre-bid meeting** will be held at 10:00 A.M. (Local Time) on Wednesday, July 31, 2024, in the Norman E. Yoder Council Chambers located at 206 East Ninth Street, Auburn, IN 46706. All prime contractors, subcontractors, small, minority or women-owned enterprises, and other interested parties are invited to attend.

The Project will be constructed in one (1) contract which is defined and outlined as follows:

Memorial Park Improvements Project:

The Project will take place at Memorial Park, located at 604 Hazel St., Auburn, IN 46706 and will include: general site work and demolition necessary to accommodate the installation and construction of the proposed amenities and associated utilities; construction of a new 1,250 square foot, ADA compliant restroom with a 920 square foot attached shelter; installation of approximately 4,000 lineal feet of 10' wide asphalt pedestrian pathways throughout the park with 8 benches; installation of 8 concrete fitness nodes with equipment; installation of 2 ADA compliant combination drinking fountain/hand sanitizing stations with shade structures; construction of a new community meeting node with memorial space and performance space with shade structure; rehabilitation of the existing basketball court; construction of a new pickleball facility with 6 courts; installation of shade structures at the pickleball and basketball courts; construction of concrete pads for the grilling area and permanent cornhole game; and installation of new neighborhood ball diamond.

Plans and Specification for the Project are on file and may be examined at the following locations:

Plans, specifications, bid forms, and instructions to bidders are available, for a deposit of \$50 per physical set. A check must be transmitted to Eastern Engineering Supply Reprographics, 1239 Wells St., Fort Wayne, Indiana 46808 (Phone: 260-426-3119 or FAX: 260-426-3101). The check shall be made payable to MartinRiley architects engineers. Sets may be purchased or downloaded online at: <http://distribution.easternengineering.com>. The deposit will be refunded provided a bid is submitted and said plans and specifications are returned to Eastern Engineering Supply Reprographics in good order within ten (10) days of the bid date.

The work to be performed and the bid to be submitted shall include sufficient and proper sums for all general construction, mechanical installation, labor, materials, permits, licenses, insurance, and so forth incidental to and required for the construction of the facilities.

Each bid must be enclosed in a sealed envelope bearing the title of the Project and the name and address of Bidder. All bids must be submitted on the bid forms as identified in the Contract Documents and Specifications.

Each bid shall be accompanied by a certified check or acceptable bidder's bond made payable to the Owner, in a sum of not less than five percent (5%) of the total amount of the highest aggregate bid, which check, or bond will be held by the Owner as evidence that the bidder will, if awarded the contract, enter into the same with the Owner upon notification from him to do so within ten (10) days of said notification.

Bids of "equivalent" or "approved equal" items of substantially the same quality, style, and features are invited. However, to receive consideration, such equivalent bids must be accompanied by sufficient descriptive literature and/or specifications to clearly identify the units and provide for competitive evaluation. Substitution requests should follow instructions found in the specifications in section 01 1500 Procurement Substitution Procedures.

Approved performance and payment bonds guaranteeing faithful and proper performance of the work and materials, to be executed by an acceptable surety company, will be required of the Contractor at the time of contract execution. The bonds will be in the amount of 100% of the Contract Price and must be in full force and effect throughout the term of the Construction Contract plus a period of twelve (12) months from the date of substantial completion.

The Owner reserves the right to reject any bid, or all bids, or to accept any bid or bids, or to make such combination of bids as may seem desirable, and to waive any and all informalities in bidding. Any bid may be withdrawn prior to the above scheduled time for the opening of bids or authorized postponement thereof. Any bid received after the time and date specified shall not be considered. No bid may be withdrawn after the scheduled closing time for receipt of bids for at least ninety (90) days.

A conditional or qualified Bid will not be accepted.

Award will be made to the low, responsive, responsible bidder. The low, responsive, responsible bidder must not be debarred, suspended, or otherwise be excluded from or ineligible for participation in federally assisted programs under Executive Order 12549.

All applicable laws, ordinances, and the rules and regulations of all authorities having jurisdiction over construction of the project shall apply to the project throughout.

Bids shall be properly and completely executed on bid forms included in the Specifications. Bids shall include all information requested by Indiana Form 96 (Revised 2010) included with the Specifications. Under Section III of Form 96, the Bidder shall submit a financial statement. A copy of the proposed Financial Statement to be submitted with the bid is included in the bid documents section to these specifications. The Owner may make such investigations as deemed necessary to determine the ability of the Bidder to perform the work and the Bidder shall furnish to the Owner all such information and data for this purpose as the Owner may request. The Owner reserves the right to reject any bid if the evidence submitted by, or investigation of, such Bidder fails to satisfy the Owner that such Bidder is properly qualified to carry out the obligations of the Agreement and to complete the work contemplated therein.

Each Bidder is responsible for inspecting the Project site(s) and for reading and being thoroughly familiar with the Contract Documents and Specifications. The failure or omission of any Bidder to do any of the foregoing shall in no way relieve any Bidder from any obligation with respect to its Bid.

Contractors and subcontractors are required to pay in accordance with the prevailing wage rates on the project which shall not be less than the Federal Davis-Bacon wage scale published by the U.S. Dept. of Labor per Davis Bacon Wage Decision #: IN20240002. *Note: The wage decision is subject to change and the one in effect on the date of the bid opening will be applicable to the total project so long as the contract award occurs within 90 days of bid opening. If not, the applicable wage decision becomes the one that is in effect on the date that contracts are signed.*

Bidders on this work shall be required to comply with the provisions of the President’s Executive Order No. 11246, as amended. The Bidders shall also comply with the requirements of 41 CFR Part 60 - 4 entitled Construction Contractors - Affirmative Action Requirements. A copy of 41 CFR Part 60 - 4 may be found in the Supplemental General Conditions of the Contract Documents and Specifications.

The Bidders attention is also called to the “Minority/Women Business Participation” requirements contained in the Project Specifications. The Indiana Office of Community and Rural Affairs has adopted a State goal of 10% participation for minority and women-owned businesses for construction related or purchase related contracts for the work.

This project is being funded in part through the Indiana Office of Community and Rural Affairs Hoosier Enduring Legacy Program (HELP) utilizing Community Development Block Grant CARES Act (CDBG-CV) funding from the Department of Housing and Urban Development (HUD). As such, the Contractor must meet guidelines and practices established by the Indiana Office of Community and Rural Affairs and appropriate federal regulations including: 1) Executive Order 11246, 2) Section 3 of the Housing and Community Development Act of 1968, as amended, 3) Certification of Non-Segregated Facilities, 4) OMB Circular A-102, 5) Title VI of the Civil Rights Act of 1964, 6) Section 504, Rehabilitation Act of 1973, 7) Age Discrimination Act of 1975, 8) Executive Order 12138, 9) Conflict of Interest Clause, 10) Retention and Custodial Requirements for Records Clause, 11) Contractors and Subcontractors Certifications, and others that may be appropriate or necessary.

Buy America Build America Act (BABA) requirements do not apply to this project. Since OCRA received their CDBG-CV allocation being utilized to fund this HELP project from HUD prior to November 15, 2022, per the Waiver described in Docket No. 6331-N-10A, this project is exempt from the BABA requirements.

Contract procurement is subject to the federal regulations contained in the OMB Circular A-102, Sections B and O and the State of Indiana requirements contained in IC-36-1-9 and IC-36-1-12.

Any contract(s) awarded under this Advertisement for Bids are expected to be funded in part by a grant from the Department of Housing and Urban Development, as administered by the Indiana Office of Community and Rural Affairs. Neither the United States nor any of its departments, agencies or employees is or will be a party to this Advertisement for Bids or any resulting contract.

Pursuant to Chapter 5, 5-4 of the Labor Standards Administration and Basic Enforcement Handbook 1344.1 Rev 2; “No contract may be awarded to any contractor that is debarred, suspended or otherwise ineligible to participate in Federal or Federally assisted contracts or programs. Any contract awarded to a prime contractor or subcontractor that is found to be ineligible for award must be terminated immediately.” Prior to contract award prime contractors are to be actively registered or seeking registration with SAM.gov to determine eligibility/debarment status.

By the order of the City of Auburn Board of Public Works & Safety.

Dated this 19th day of July, 2024. Attest: Lorrie K. Pontius, Clerk-Treasurer

July 19, 2024 – 1st Advertisement (Please verify/confirm dates. These dates will not be printed in advertisement)
July 30, 2024 – 2nd Advertisement

**SECTION 00 2213
SUPPLEMENTARY INSTRUCTIONS TO BIDDERS**

GENERAL

AIA DOCUMENT A701, "INSTRUCTIONS TO BIDDERS - CURRENT EDITION", ARTICLES 1 THROUGH 8, AS PUBLISHED BY THE AMERICAN INSTITUTE OF ARCHITECTS, 1735 NEW YORK AVENUE, N.W., WASHINGTON, D.C. 20006 ARE HEREBY, EXCEPT AS MAY BE INCONSISTENT HEREWITH, MADE PART OF THESE BIDDING DOCUMENTS. THESE INSTRUCTIONS TO BIDDERS APPLY EQUALLY TO AND ARE PART OF ALL BIDDING DOCUMENTS BETWEEN THE OWNER AND EACH SEPARATE CONTRACTOR FOR THE WORK UNDER THIS PROJECT.

SUPPLEMENTARY INSTRUCTIONS TO BIDDERS:

THE FOLLOWING SUPPLEMENTS MODIFY, CHANGE, DELETE FROM OR ADD TO THE "INSTRUCTIONS TO BIDDERS - CURRENT EDITION", AIA DOCUMENT A701. WHERE ANY ARTICLE OF THE INSTRUCTIONS TO BIDDERS IS MODIFIED OR ANY PARAGRAPH, SUBPARAGRAPH OR CLAUSE THEREOF IS MODIFIED OR DELETED BY THESE SUPPLEMENTS, THE UNALTERED PROVISIONS OF THAT ARTICLE, PARAGRAPH, SUBPARAGRAPH, OR CLAUSE SHALL REMAIN IN EFFECT.

ARTICLE 1 DEFINITIONS**1.6, REVISE THE PARAGRAPH TO READ AS FOLLOWS:**

1.6 An Alternate Bid (or Alternate) is an amount stated in the Bid to be added to or deducted from the amount of the Base Bid if the corresponding change in the Work, as described in the Bidding Documents, is accepted. Alternates are identified in the Contract Documents.

1.6.1, ADD THE FOLLOWING NEW SUBPARAGRAPH:

1.6.1 A Voluntary Alternate Bid (or Voluntary Alternate) is an amount proposed by the Bidder as alternative materials, products, or equipment not described in the Bidding Documents or otherwise approved as a substitution as identified under paragraph 3.3 Substitutions. Bids proposed in this manner are to be clearly identified as amounts to be added to, deducted from, or in lieu of the Base Bid or Alternate Bids described in the Bidding Documents. Voluntary Alternates shall be subject to the criteria of paragraph 3.3. Substitutions, before it will be considered or accepted. The Architect's decision of acceptance or non-acceptance of a proposed Voluntary Alternate shall be final.

1.10, ADD THE FOLLOWING PARAGRAPH:

1.10 The Owner is The City of Auburn, 210 East Ninth Street, Auburn, Indiana, 46706.

1.11, ADD THE FOLLOWING PARAGRAPH:

1.11 The Architect is:

MartinRiley architects|engineers
221 West Baker Street; Fort Wayne, Indiana 46802
Phone: (260) 422-7994 Fax: (260) 426-2067

ARTICLE 2 BIDDER'S REPRESENTATIONS**2.1.7, ADD THE FOLLOWING PARAGRAPH:**

2.1.7 No Bidder, after the award of the Contract, shall be allowed any extra compensation for reasons of their failure to inform themselves fully, prior to bidding, of all requirements of the Contract Documents, drawings, specifications and circumstances of the building site.

2.1.8, ADD THE FOLLOWING PARAGRAPH:

2.1.8 Bidders represent that at the time Bids are submitted for consideration, they have no questions regarding ambiguity or omissions and are submitting Bids that will result in a complete project.

ARTICLE 3 BIDDING DOCUMENTS**3.1.1.1, ADD THE FOLLOWING SUBPARAGRAPH:**

3.1.1.1 Bidding Documents are on file and are available at the office of Eastern Engineering, 1239 Wells Street, Fort Wayne, Indiana 46808, upon receipt of a deposit of: \$50 per set. This deposit will be refunded provided a bid is submitted and said plans and specifications are returned in good order within ten (10) days of the bid date.

3.1.1.2, ADD THE FOLLOWING SUBPARAGRAPH:

3.1.1.2 The following will be used to determine the condition of the Bidding Documents sets returned, including addenda, for deposit to be returned:

1. Sets to be returned as originally bound;
2. No missing sheets;
3. All printed information being clearly readable;
4. No dark colored markings or dark written lines;
5. No excessive multi-colored lines or markings.

3.2.1.1, ADD THE FOLLOWING SUBPARAGRAPH:

3.2.1.1 In the event of an inconsistency between the Drawings and the Specifications or within either Document that is not clarified by addenda, the better quality or greater quantity of Work shall be provided in accordance with the Architect's interpretation.

3.2.4, ADD THE FOLLOWING NEW SUBPARAGRAPH:

3.2.4 Questions for this project shall be directed to:
Project Manager: Jessica Franke
Phone: (260) 422-7994 Fax: (260) 426-2067
email: jfranke@martin-riley.com

3.3.1.1, ADD THE FOLLOWING SUBPARAGRAPH:

3.3.1.1 Where specific materials, trade names, or models of certain manufacturers are specified, it is done to establish a basis of durability, efficiency, appearance and simplification of maintenance, and not for the purpose of limiting competition. If a bidder wishes to use a different product in the bid to be submitted, then that product must be submitted for approval following the submittal procedures defined elsewhere within this specification. The decision of the Architect and Owner shall be final.

3.3.2, ADD THE FOLLOWING AFTER "ARCHITECT'S" IN THE LAST LINE:

"...and Owner's..."

ARTICLE 4 BIDDING PROCEDURES**4.1.2.1, ADD THE FOLLOWING SUBPARAGRAPH:**

4.1.2.1 Failure to bid requested alternates, unit prices or fill in any blanks will be considered justification for rejection of the bid.

4.1.8, ADD THE FOLLOWING NEW PARAGRAPH:

4.1.8 Proposals will be "STIPULATED SUM" for the projects as listed in Division 1, GENERAL REQUIREMENTS and in the Proposal Form Supplement.

4.2.1, ADD THE FOLLOWING TWO NEW SENTENCES:

Each bid shall be accompanied by either a bid bond or a certified check drawn in favor of the Owner for an amount not less than five percent (5%) of the maximum bid or bids submitted. The bid bond pledges that the Bidder will enter into a Contract with the Owner on the terms stated in the Bid and will, if required, furnish bonds covering the faithful performance of the Contract and payment of all obligations arising thereunder.

6.01 4.2.7, ADD THE FOLLOWING NEW PARAGRAPH:

- A. 4.2.7 Bid Bond, if submitted, shall be written by a surety firm acceptable to the Owner, and shall guarantee that: if the Bidder is awarded Contract with Owner within thirty (30) days from the date bids were received, he will enter into a contract with the Owner within five (5) days after receipt of notice of award, and that within ten (10) days of such notice he will provide Performance and Labor and Material Payment Bond for 100% of the amount of the Contract. Notice of award or rejection shall be given within 30 days of the receipt of bids.

4.3.5, ADD THE FOLLOWING NEW SUBPARAGRAPH:

4.3.5 Deliver copies of the bid and any other documents required in duplicate on or before the time and at the location specified.

ARTICLE 5 CONSIDERATION OF BIDS**5.1.2, ADD THE FOLLOWING PARAGRAPH**

5.1.2 The Owner reserves the right to waive any and all formalities.

5.2, MODIFY THE FIRST SENTENCE TO READ:

The Owner reserves the right to reject any or all Bids and is not obligated to accept the lowest or any combination of Bids.

5.3.1, ADD THE FOLLOWING SENTENCE TO THE END OF THE PARAGRAPH:

....Notice of acceptance or rejection of Bids by the Owner shall be given within 90 days of the receipt of Bids.

ARTICLE 7 PERFORMANCE BOND AND PAYMENT BOND**7.1.1, MODIFY THE FIRST SENTENCE TO READ:**

7.1.1 The Bidder shall furnish bonds, i.e, Performance Bond and Payment Bond covering the faithful performance of the Contract and payment of all obligations arising thereunder, in an amount specified in the General and Supplementary Conditions of the Contract.

ADD NEW ARTICLE AS FOLLOWS:**ARTICLE 9 TIME****9.1 ADD NEW PARAGRAPH AND SUBPARAGRAPH:****9.1 COMPLETION TIME**

9.1.1 It is the intent of the Owner to begin work after the 30th of September 2024 and have work substantially complete and suitable for use before the 31st of July, 2025.

9.1.2 It is the intent of the Owner for the project to reach final completion on or before the 14th of August, 2025.

10.019.2, ADD THE FOLLOWING NEW PARAGRAPH

- A. 9.2 FAILURE TO COMPLETE WORK:
1. 9.2.1 For each calendar day that the Work remains incomplete after the above published completion dates, the sum of \$100.00 per each site that remains incomplete after the above published dates, will be deducted from the Contractor's Contract as liquidated damages. Due account will be taken (if any) by both the Owner and Architect for adjustments to the specified time. Liquidated damages will not be assessed to sites that were completed prior to the specified completion dates and are waiting for final inspection. Liquidated damages will also be assessed for each calendar day beyond the specified date on the Certificate of Substantial Completion to complete any of the corrective action or clean up work as identified on the final inspection.

ADD NEW ARTICLE AS FOLLOWS:**ARTICLE 10 MEETINGS****10.1, ADD NEW PARAGRAPH AND SUBPARAGRAPH:**

10.1 PREBID CONFERENCE:

10.1.1 A prebid conference with the Owner, Architect, and Bidders will be held at 10:00 AM local time, 31 July 2024, at the Norman E. Yoder Council Chambers located at 206 East Ninth Street, Auburn, IN 46706.

END OF SECTION

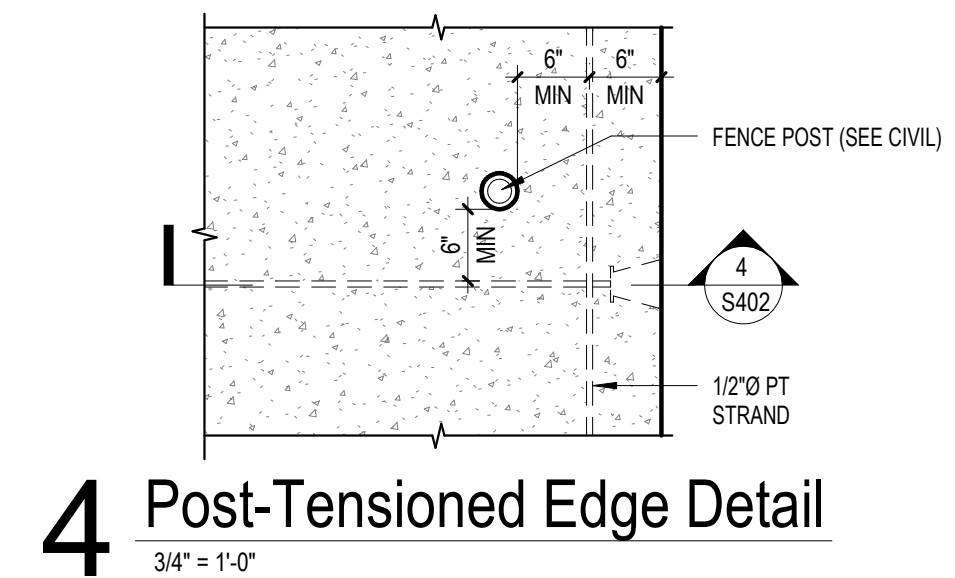
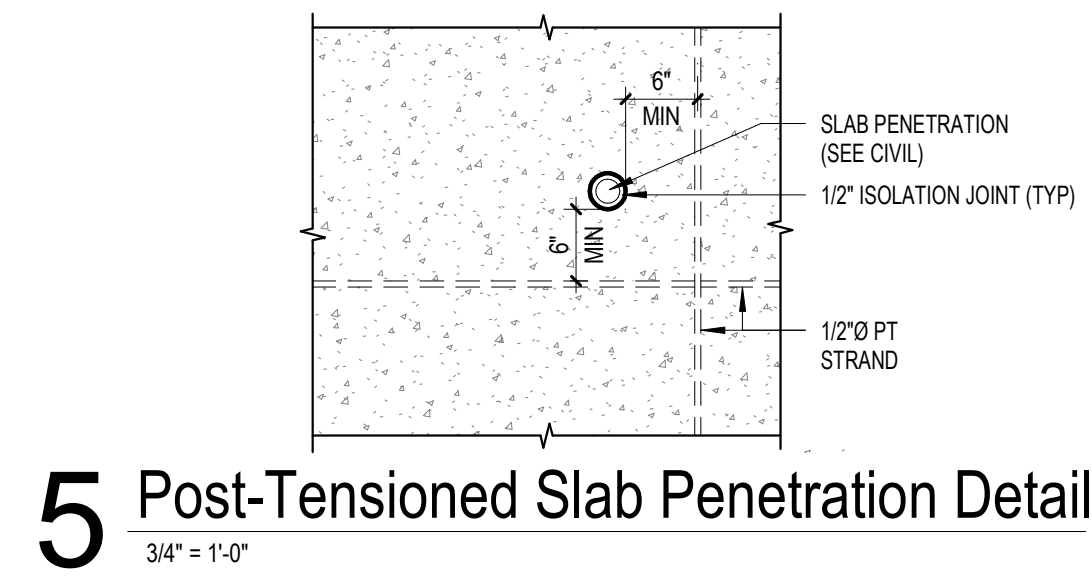

Work Description Notes

- PLACE FOUR INCH THICK SLAB-ON-GROUND OVER A MINIMUM SIX INCH THICK COMPACTED CLEAN GRANULAR BASE COURSE (CRUSHED LIMESTONE AGGREGATE MEETING INDOT NO. 53 GRADUATION REQUIREMENTS), REINFORCE SLAB WITH 6 x 6 - W14 x W14 WELDED WIRE FABRIC (WWF). PLACE REINFORCEMENT WITH TWO INCHES OF COVER FROM THE TOP SURFACE OF THE SLAB.
- PLACE FOUR INCH THICK POST-TENSIONED SLAB-ON-GROUND OVER A MINIMUM SIX INCH THICK COMPACTED CLEAN GRANULAR BASE COURSE (CRUSHED LIMESTONE AGGREGATE MEETING INDOT NO. 53 GRADUATION REQUIREMENTS). PRESTRESSING TENDONS SHALL BE UNBONDED.
- CONTRACTION JOINTS ARE PROHIBITED IN PICKLEBALL COURT SLAB-ON-GROUND.

Foundation Plan Notes

- PLAN REFERENCE ELEVATIONS:
 - a. TOP OF CONCRETE SLAB = 100'-0"
 - b. STAGE PAVILION = 101'-6"
 - c. WATER FOUNTAIN PAD = 100'-0"
 - d. BOTTOM OF GRADE BEAM = 97'-0"
 - e. TOP OF FOUNDATION WALL = 100'-0"
- BOTTOM OF FOUNDATIONS TO BE LOCATED A MINIMUM OF 3'-0" BELOW FINISH GRADE.
- CENTER ALL FOOTINGS ON WALL, PEDESTAL, PIER OR COLUMN ABOVE, UNLESS OTHERWISE INDICATED.
- WHERE COLUMN FOOTINGS INTERSECT FOUNDATION WALL FOOTINGS, EXTEND ALL WALL REINFORCEMENT DOWELS DOWN TO BOTTOM LAYER OF COLUMN FOOTING REINFORCEMENT.
- WHERE FOUNDATION WALL INTERSECTS COLUMN PEDESTAL, EXTEND ALL LONGITUDINAL FOUNDATION WALL REINFORCEMENT THROUGH COLUMN PEDESTAL.
- WHERE FOUNDATION WALL FOOTING INTERSECTS COLUMN FOOTING, EXTEND ALL LONGITUDINAL STEM WALL FOOTING REINFORCEMENT THROUGH COLUMN FOOTING.
- SPREAD BARS AROUND SMALL OPENINGS AND SLEEVES IN SLABS AND WALLS WHERE POSSIBLE AND WHERE BAR SPACING WILL NOT EXCEED 1.5 TIMES THE NORMAL SPACING. DISCONTINUE BARS AT LARGE OPENINGS WHERE NECESSARY AND PROVIDE AN AREA OF REINFORCEMENT EQUAL TO THE INTERRUPTED REINFORCEMENT, DISTRIBUTING ONE HALF OF THIS REINFORCEMENT EACH SIDE OF THE OPENING (CLASS B TENSION LAP SPLICED). HOLES LARGER THAN 12 INCHES IN ANY DIRECTION SHALL HAVE 1 - #5 x 4'-0" DIAGONAL BARS IN BOTH FACES AT EACH CORNER.
- ALL OPENINGS THROUGH WALLS, SLABS OR OTHER STRUCTURAL ELEMENTS NOT DETAILED ON THE DRAWINGS MUST BE LOCATED BY THE CONTRACTOR AND SHOWN ON THE APPLICABLE REINFORCING STEEL SHOP DRAWINGS. THE FINAL LOCATION OF ALL OPENINGS BE REVIEWED BY THE ENGINEER OF RECORD BEFORE THE CONCRETE IS PLACED.

New Construction and Renovation Work for:

Memorial Park Improvements

604 Hazel St
Auburn, IN



221 West Baker Street
Fort Wayne, Indiana 46802
pho 260.422.7994
fax 260.426.2067

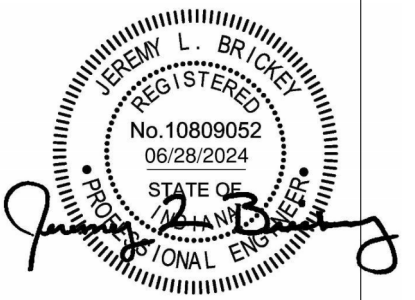

ALL DESIGN, DIMENSIONS AND NOTATIONS ON THIS DRAWING ARE OWNED BY AND THE PROPERTY OF MARTIN RILEY ARCHITECTS+ENGINEERS, INC. NO PART OF THIS DRAWING IS TO BE REPRODUCED OR TRANSMITTED IN ANY FORM OR BY ANY MEANS, ELECTRONIC OR MECHANICAL, INCLUDING PHOTOCOPYING, RECORDING, OR BY ANY INFORMATION STORAGE AND RETRIEVAL SYSTEM, WITHOUT THE WRITTEN PERMISSION OF MARTIN RILEY ARCHITECTS+ENGINEERS, INC. ANY REPRODUCTION OR TRANSMISSION OF THIS DRAWING WITHOUT THE WRITTEN PERMISSION OF MARTIN RILEY ARCHITECTS+ENGINEERS, INC. SHALL BE PROHIBITED. CONTRACTORS SHALL BE RESPONSIBLE FOR ALL DIMENSIONS AND CONDITIONS ON THE JOB AND THIS OFFICE WILL BE NOTICED OF ANY VARIATION FROM THE DIMENSIONS AND CONDITIONS ON THE DRAWING. ANY DIMENSIONS AND CONDITIONS SHALL BE SUBJECT TO THE REQUIREMENTS OF THE CONTRACT DOCUMENTS BEFORE PROCEEDING WITH FABRICATION.

REVISION	DATE
1 Addendum 1	2024-07-19

DRAWN BY: NMS
COMMISSION NUMBER: F23059
REVIEWED BY: JLB
DATE: 2024-07-16

S102

FOUNDATION PLANS

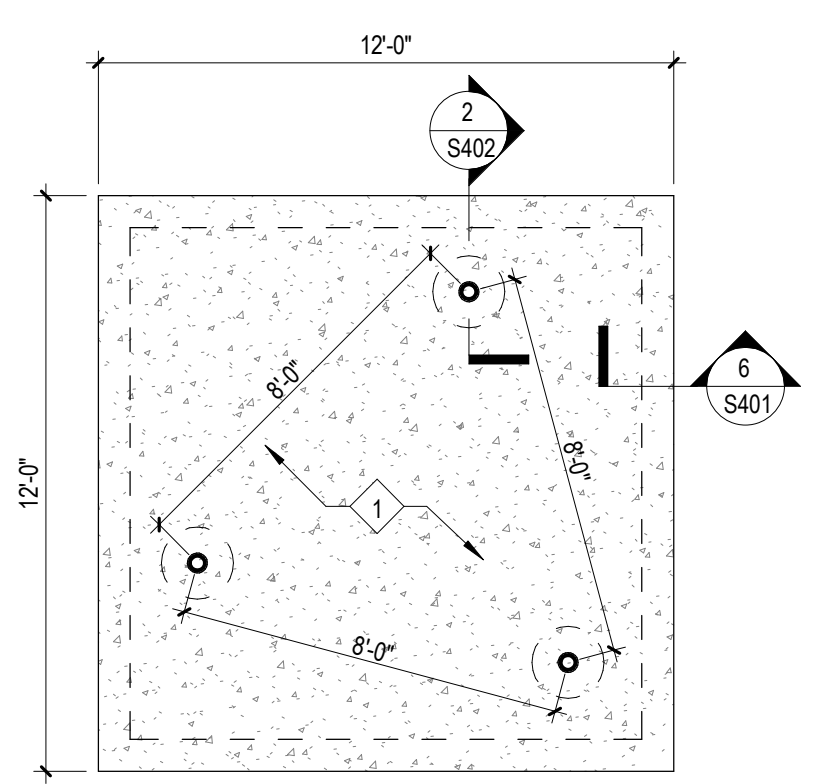
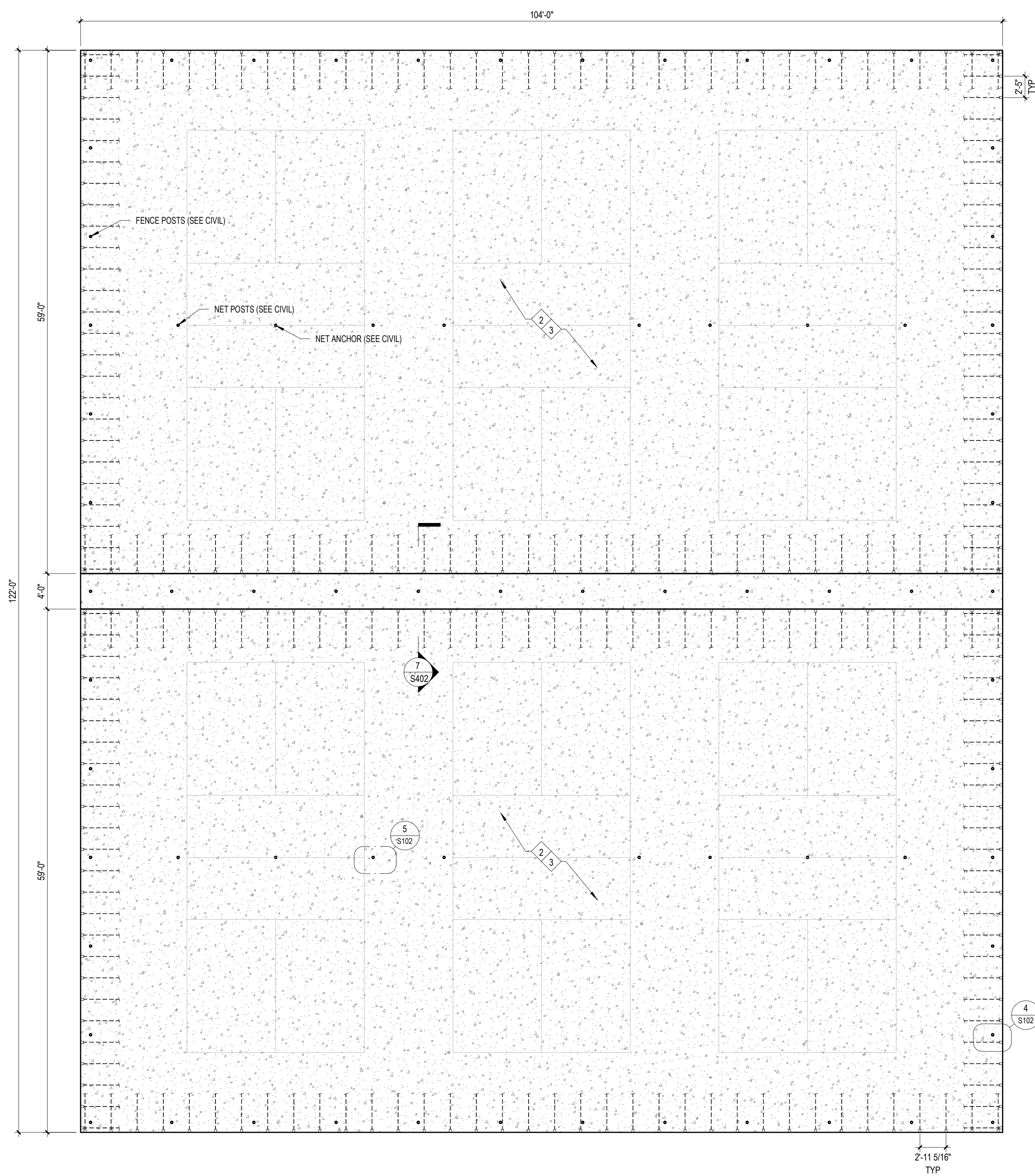

3 Foundation - Water Fountain
1/4" = 1'-0"

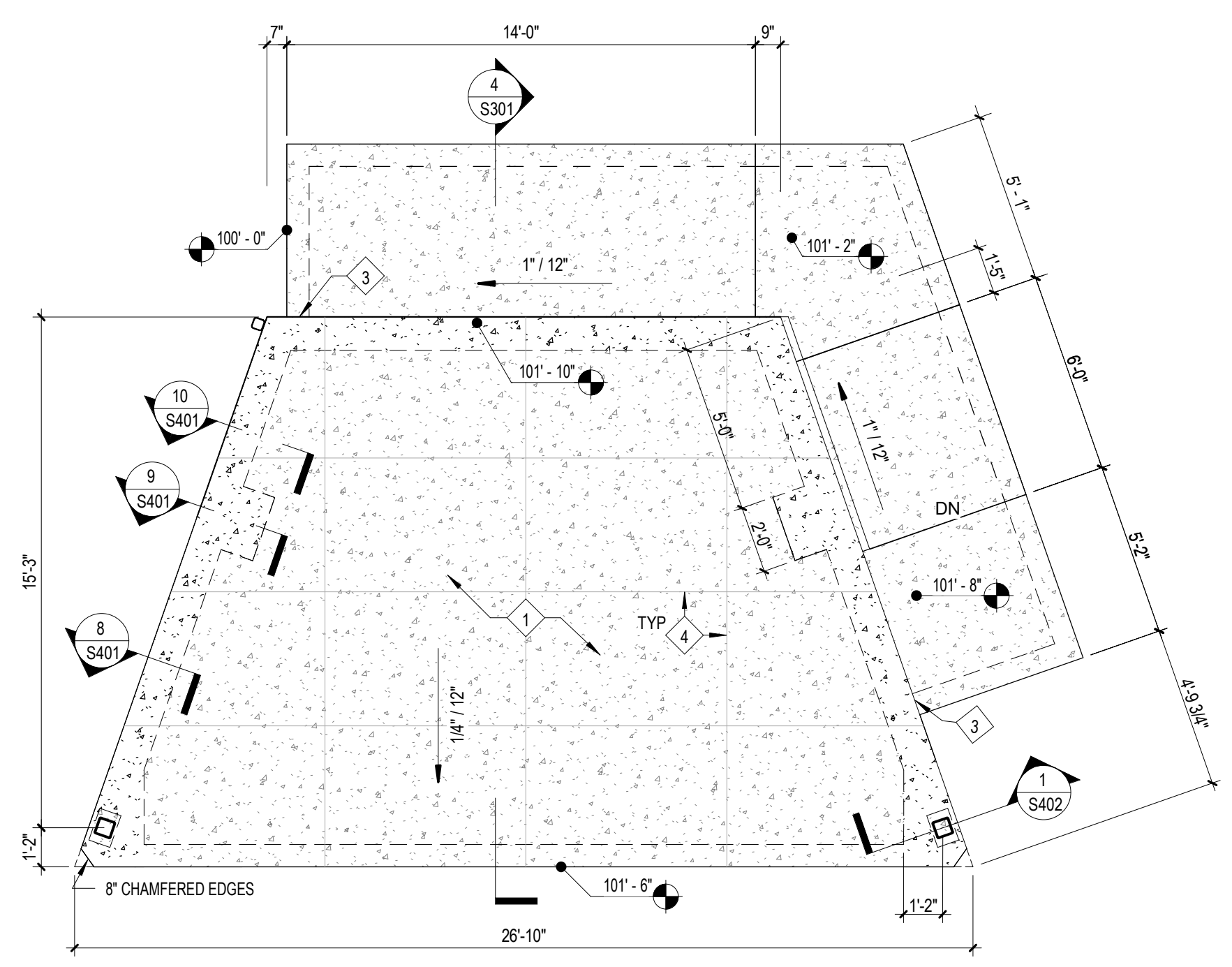

1 Foundation - Stage Pavilion
1/4" = 1'-0"

2 Foundation - Pickleball Courts
1/8" = 1'-0"

F23059 Memorial Park Improvements
 7/18/2024 4:04:29 PM
 \projects\Projects\2023\Projects\F23059 Memorial Park Auburn\Drawings\F23059 Memorial Park Auburn - S102.rvt
 S102.DCD

City of Auburn Memorial Park Improvements



604 Hazel St
Auburn, IN



REVISION	DATE
1 Addendum 1	2024-07-19

SYMBOLS KEY

EARTHWORK	WOOD	INSULATION	MASONRY
EARTH UNDISTURBED FILL EARTH COMPACTED FILL GRANULAR FILL SAND	LUMBER FINISH WOOD WOOD BLOCKING PLYWOOD	BATT/OOSE INSULATION RIGID INSULATION	CONCRETE MASONRY UNIT BRICK
CONCRETE	GLASS	METALS	
CONCRETE	GLASS GLASS BLOCK	STEEL ALUMINUM	

AREA MAP

INDEX OF DRAWINGS

T101 TITLE SHEET	A001 LIFE SAFETY PLAN
G101 GENERAL DETAILS	A101 RESTROOM PLANS
C101 EXISTING DEMOLITION PLAN	A102 SHADE STRUCTURES
C200 OVERALL SITE LAYOUT PLAN	A103 STAGE PLANS AND DETAILS
C201 ENLARGED SITE LAYOUT PLAN	A201 BUILDING ELEVATIONS
C202 ENLARGED SITE LAYOUT PLAN	A401 WALL & BUILDING SECTIONS
C203 ENLARGED SITE LAYOUT PLAN	A410 SIGNAGE DETAILS
C301 ENLARGED GRADING PLAN	A601 FINISH, DOOR, AND WINDOW SCHEDULES AND DETAILS
C302 ENLARGED GRADING PLAN	A602 INTERIOR ELEVATIONS
C303 ENLARGED GRADING PLAN	R101 ROOF PLAN
C400 UTILITY PLAN	R102 ROOF DETAILS
C800 SITE DETAILS	MP101 MECHANICAL AND PLUMBING PLAN
C801 SITE DETAILS	E100 ELECTRICAL SITE PLAN
C802 SITE DETAILS	E101 ELECTRICAL FLOOR PLANS
C900 EROSION CONTROL PLAN	E501 ELECTRICAL SCHEDULES AND DETAILS
C901 EROSION CONTROL DETAILS	
D101 DEMOLITION DRAWINGS	
S001 STRUCTURAL SPECIFICATIONS	
S002 STRUCTURAL SPECIFICATIONS	
S101 FOUNDATION PLANS	
S102 FOUNDATION PLANS	
S201 FRAMING PLANS	
S301 STRUCTURAL SECTIONS	
S401 FOUNDATION DETAILS	
S402 FOUNDATION DETAILS	
S501 STRUCTURAL DETAILS	

OFFICE ROOM NAME: 104, ROOM NUMBER

DETAIL DESCRIPTION NOTES

- XX WORK DESCRIPTION NOTE
- XX DEMO WORK DESCRIPTION NOTE
- XX DETAIL DESCRIPTION NOTES
- XX WINDOW OR ROOF AREA

SYMBOLS KEY

NON-ASBESTOS BUILDING MATERIAL TEST LOCATION	ASBESTOS BUILDING MATERIAL TEST LOCATION
L0001	L0001

ENLARGED PLAN/DETAIL

1 A101 SHEET

DETAIL

1 A101 SHEET

ELEVATIONS

1 A101 SHEET

WALL SECTION

1 A101 SHEET

NEW RESTROOM PAVILLION

ARCHITECT

JACK E. DANIEL
REGISTERED ARCHITECT
No. ARS100226
STATE OF INDIANA

ENGINEER

TORREY D. EHRMAN

ENGINEER

JEREMY L. BRICKEY
REGISTERED PROFESSIONAL ENGINEER
No. 10809052
09/28/2024
STATE OF INDIANA

ENGINEER

JEFFREY J. NEUMANN
REGISTERED PROFESSIONAL ENGINEER
No. 12300217
06/28/2024
STATE OF INDIANA

ENGINEER

RONALD P. SCHEELE JR.
REGISTERED PROFESSIONAL ENGINEER
No. 10403287
06/28/2024
STATE OF INDIANA

MARTIN RILEY
architects • engineers

221 West Baker Street
Fort Wayne, Indiana 46802

pho 260.422.7994
fax 260.426.2067

DATE: 2024-07-16

SET NUMBER

COMMISSION NO. F23059

Memorial Park Improvements