



Addendum No. 2

Date: July 30, 2024
Project: EHES Media Center Renovation
Project #: IN24004
Bid Date: August 6, 2024

General Note:

General description of drawings or documents included in this addendum.

The original Specifications and Drawings dated July 16, 2024, for the project referenced above are amended as noted in this Addendum No. 2. Items changed or added by this addendum are to take precedence over the items or descriptions of the work in the project specifications and the drawings. Items not mentioned in this addendum are to remain as described in the original plans and specifications.

To: All Holders of Contract Documents:

Your attention is directed to the following interpretations of, changes in, and additions to the Specifications and Drawings for the EHES Media Center Renovation, located at 10450 250N, Charlottesville, IN 46117.

Question & Answer:

- 1. Question:** HVAC controls and commissioning are by the owner. Please confirm.
Answer: HVAC Controls and programming provided by owner.
- 2. Question:** What are the expectations for working hours and noise during construction?
Answer: Owner acknowledges construction noise and disruptions from time to time. They will try to accommodate whatever needs to be done. There may be some testing periodically that they will request for some quick hours but keeping things moving is the goal.
- 3. Question:** My acoustical ceiling sub is asking what type of ceiling tile to price out. The project manual in addendum 1 has two sections for Acoustical Tile Ceilings with the different tiles called out.
Answer: New acoustical tile to match Existing. Provide Armstrong Cortega #823.
- 4. Question:** The drawing says to check the spec for the ceiling tile. 9 51 10 / Section 2.2 - B The spec calls "ACT-1" Armstrong Ultima #1910 & 9 51 10 / Section 2.2 - C "ACT-2" Ultima Health Zone #1445 which one do we use? NOTE: I noticed in the walk-through that



the existing tile all around was Armstrong Cortega #823. They don't want the ceiling tile to match all the others?

Answer: New acoustical tile to match Existing. Provide Armstrong Cortega #823.

5. **Question:** Wall 3C is a 1hour rated wall, Spec 9 21 16 / Section 2.2 – G Top of wall Firestop Gasket, I sent this off to my Hilti rep. for pricing and he did not know what I was asking for. Could I get a better explanation of this material

Answer: Firestop Gasket basis of design: Hilti CFS-TTS MD Firestop Top Track Seal. Contractor to confirm 1-HR wall head connection is to metal deck. If another decking material is existing, coordinate firestopping with architect.

6. **Question:** In the spec book 9 21 16 / Section 3.2 – D, I totally get the 16ga jam studs, then it says “no less than double stud at the head and jams. Does this need to be a 16ga boxheader?

Answer: Yes - this needs to be a steel stud box header, sketch similar to below:

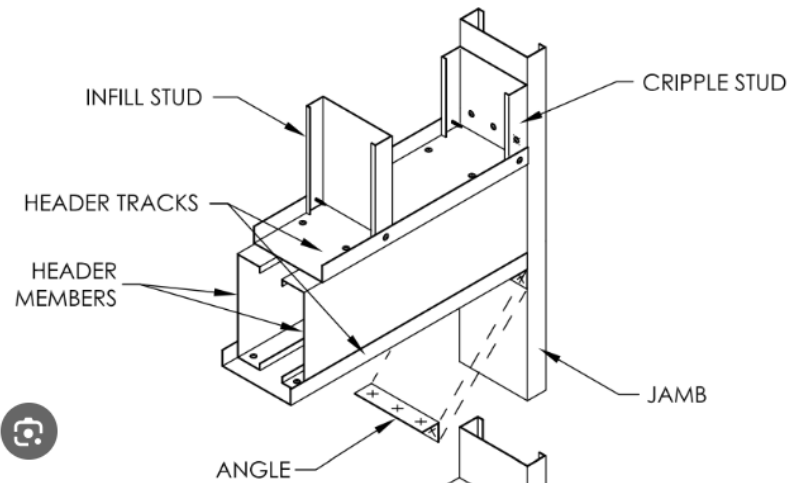

7. **Question:** In the drawings A1.01 / Wall Types 3C & 6C calls for fiberglass insulation, in the spec. book 9 21 16 / Section 1.3 – Says “Mineral-Fiber Blanket Thermal Insulation for Light Frame Construction”. Should I price thermal fiber or fiber glass insulation for these walls?

Answer: Provide fiberglass insulation at all rated wall locations.

8. **Question:** Sherwin Williams has stop making Harmony paint, its replacement is called Super Paint W/ air purifying qualities. Can you verify if this Super Paint is an acceptable replacement for the Harmony paint?

Answer: This is acceptable.



9. **Question:** A1.21 General Note C states that 2x4 Lighting is Owner Supplied. Is this correct, and are these fixtures to be removed, stored, cleaned and re-installed?
Answer: All RAB LED 2X4 fixtures will be reused. The project calls for all 2X2 fixtures to be removed and turned over to owner. Additionally, owner will supply any RAB LED 2X4 fixtures to complete the project. The contractor is responsible for adding additional hardware to dim the existing light fixtures for each area noted.
10. **Question:** It was noticed during the initial walk-through that the existing ceiling tile that will remain is Armstrong Cortega #823. Please confirm that the new ceiling tile should not match the existing tile
Answer: New acoustical tile to match Existing. Provide Armstrong Cortega #823
11. **Question:** Detail 8K on A1.21 is labeled Enlarged Ceiling Plan – Alt #2 but this does not appear to line up with the description of Alternate #2 in spec section 012300. Can you please clarify?
Answer: Alternate 2 is Sloped nooks with plastic laminate cladding and sloped painted gypsum board ceiling finishes as shown in drawings. Includes mini-can lighting in soffits.
12. **Question:** Can you please provide additional information and details for what is expected for the acoustical treatments in detail 1K on A1.21 for Alternate #1?
Answer: Refer section 09 54 22 for information on polyester ceiling cloud.
13. **Question:** Can you please confirm that fiberglass insulation is acceptable for wall insulation as indicated on the Wall Types Table on A1.01 and that mineral wool is not required as indicated in spec section 092116-2.4-A?
Answer: Provide fiberglass insulation at all rated wall locations.
14. **Question:** Do you have a LEED coordinator? Will the coordinator perform monthly sustainable construction progress report?
Answer: Project is not pursuing LEED Certification. Refer addendum 1 (issued 07/23/2024) indicating deletion of specification section 01 81 13 Sustainable Design Requirements.
15. **Question:** Can you please confirm what the deck height is for the metal framing to extend to, I do not see a full cut section that this information is indicated on?
Answer: Contractor to verify in field all existing deck heights, connecting to new construction.
16. **Question:** Can you please confirm what deflection criteria should be used, l/120 (per Spec Section 092116-2.2-D) or L/240 (per Wall Type Construction Note on A1.01)?



- Answer:** Deflection limit shall be L/240.
- 17. Question:** Can you please confirm that moisture resistant board is required in all locations where tile backer is not indicated since it appears to be the only other gypsum board listed in spec section 092116-2.3-B?
- Answer:** Moisture resistant board is not required. In all locations where tile backer is NOT being used, provide standard type "x" gypsum board.
- 18. Question:** Can you please confirm that drying compound with paper joint tape can be used in place of the setting compound with fiberglass tape that is indicated in spec section 09216-2.4-E?
- Answer:** Drying compound with paper joint tape is acceptable.
- 19. Question:** Can you please confirm that 20GA framing material is acceptable at door openings and that 16GA material will not be required as indicated in spec section 092116-3.2-D?
- Answer:** 20GA framing is acceptable at door openings.
- 20. Question:** Can you please confirm that a Level-5 wall finish is not required behind the vinyl wallcovering?
- Answer:** A level 5 finish is not required behind the vinyl wall covering.
- 21. Question:** There is reference to spec section 017419 Construction Waste Management and Disposal, but this does not appear in the spec book.
- Answer:** Please ignore this reference. There is no Spec Section 017419 Construction Waste Management.
- 22. Question:** There are repeated questions in the bid form and form 96. Can we just answer "see bid form" to the repeated questions?
- Answer:** This is acceptable.
- 23. Question:** Is there a list of bid documents required? We are going through spec but hoping there is a full list we can cross reference against.
- Answer:** Please submit the bid form and bid security, with acknowledgement of alternates and addenda, duration time, and any exceptions. References and financials are not required but will be requested at the time of bid award to confirm the apparent low bidder.
- 24. Question:** How old is the building? Mostly concerned about pre-1978 lead requirements if they exist
- Answer:** Elementary School construction was completed in 1979.



25. **Question:** Can the subcontractor list be submitted within 24 hours after submission? The (2) bid docs ask for a list at bid, but other section says (24) hours?

Answer: This is acceptable.

Specifications Items:

Section 09 51 10 Acoustical Tile Ceiling

1. Section 2.2, B. Basis of Design Product "ACT-01"

a. Replace: "Armstrong world industries, School Zone Fine Fissured" with "Armstrong World Industries, Cortega #823."

Section 10 22 26 Operable Partition

1. Section 2.1 A. Manufacturer

a. Add: 4. CoreFlex Operable Partition 5500, as an approved equal.

Section 10 51 29 Phenolic Lockers

1. Section 2.1 Manufacturers, A. Phenolic Lockers:

a. Add: Spectrum: www.spectrumlockers.com, as an approved equal.

End of Addendum No. 2

